

SC 40RE

2 & 4 nozzle tank cleaning machine
external drive; electric drive



Key Features SC 40RE

- Removable drive
- Easy installation
- Controllable rotation
- 2 & 4 nozzle design
- Very low pressure drop
- Quiet operation
- CE rated
- Self cleaning
- High solids handling

SC 40RE

Product Summary:

The SC 40 RE is an electric driven externally powered automated tank cleaning machine. Both 2 nozzle and 4 nozzle versions are available with all wetted parts constructed of 316 stainless steel and other highly corrosion resistant materials

As none of the cleaning fluid is used to power the SC 40RE, the pressure drop across the machines is very minimal. As a result, the fluid energy from the cleaning supply pump is maximized.

The SC 40RE is a very rugged and durable tank cleaning machines; designed for demanding cleaning applications where reliability and long service intervals are required.

Quality Control, Compliances & Certifications

The SC 40RE is produced in accordance with ISO 9001 Quality Standards and our certificate of conformity and accreditation is available on request.

Typical applications for the SC 40RE are... Ethanol Plants, Paints and Coatings process vessels, Over-The-Road tankers and railcars, Totes and IBC's, and much more.

General Specifications...

Flow.....	0-300 USGPM (0-68 m ³ /h)
Inlet Pressure Range.....	50-200 PSIG (3.5-13.8 Bar)
Maximum Pressure.....	203 PSIG (14 Bar)
Nominal Operating Pressure.....	120 PSIG (8 Bar)
Maximum Temperature (Operational).....	203° F (95° C)
Maximum Temperature (Static)	252°F (122°C)
Rotation speed	1-5 RPM
Lengths.....	1.6-50 feet (0.5 - 15 meters)
Weight	83 lbs. (38 kg) @ 60" or 1.5 meters
Per additional meter (3.2808')	20.2 lbs (10 kg)
Mounting Flange (Standard)	6.00" ANSI 150# FF
	PN16 DIN150
	Others on request
Inlet Connection (Standard)	2.00" ANSI 150# FF
	PN16 DN50
	Others on request
Materials in contact with fluid.....	AISI 316; PTFE; other corrosion resistant materials
Lubrication (Gun Unit).....	Cleaning media
Motor.....	120 VAC 60 Hz; 3x400 VAC; 230 VAC; 24 VAC

Customization available on request.

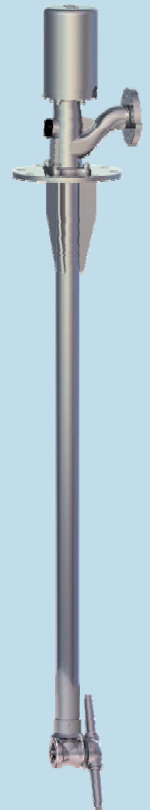

1035.2009.02.06

SC 40RE

2 & 4 nozzle tank cleaning machine
external drive; electric

Pressure & Flow

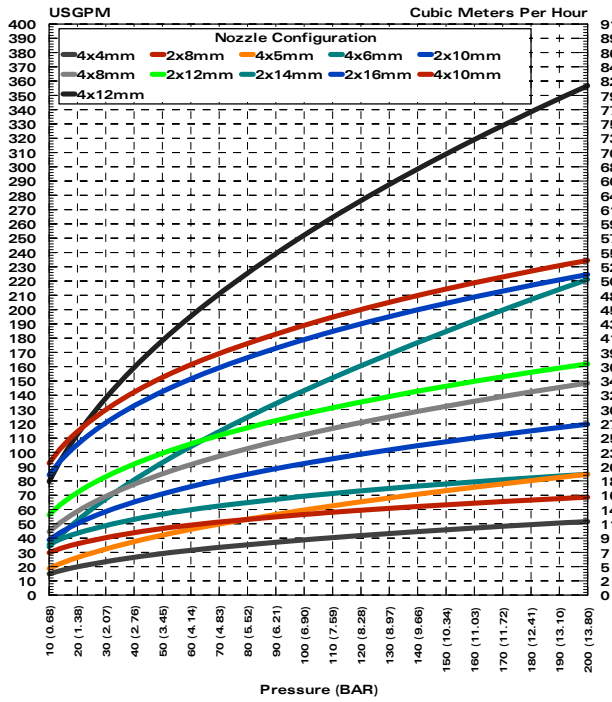

General Dimensions

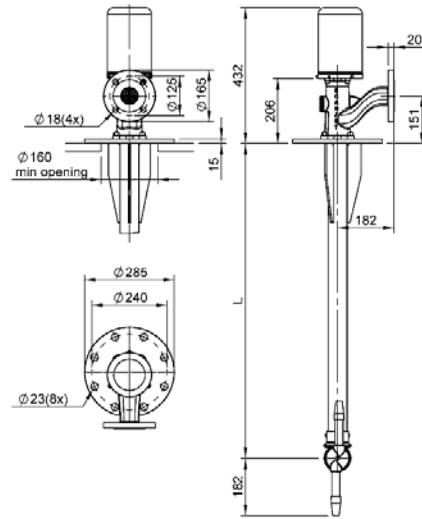

All dimensions are in mm.

Standard Flanges:

Mounting : 6.00" ANSI 150# FF

Inlet : 2.00" ANSI 150# FF

Others on request

Jet Length

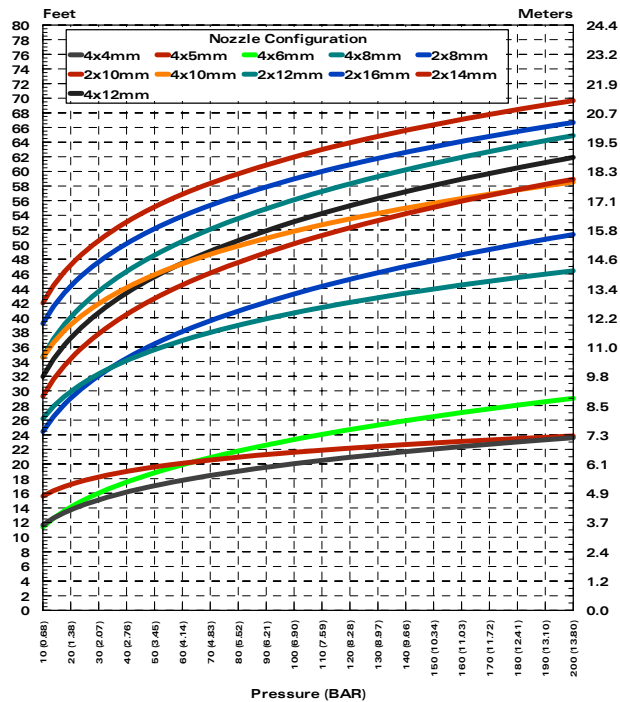

Cycle Times

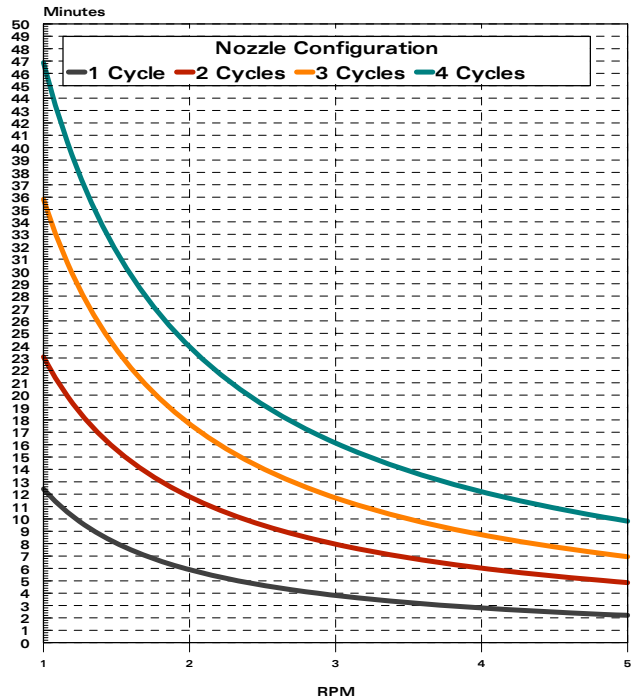

1035.2009.02.06



Scanjet, Inc.
15200 Middlebrook Drive; Suite E
Houston, Texas 77058 - USA
Phone: 281.480.4041
Fax: 713.513.5883
Website: www.scanjetinc.com
Email: sales@scanjetinc.com

